

GaAs HEMT MMIC MODULATOR DRIVER AMPLIFIER, 0.5 - 65 GHz

Typical Applications

This HMC-AUH312 is ideal for:

- Fiber Optic Modulator Driver
- Fiber Optic Photoreceiver Post Amplifier
- Gain Block for Test & Measurement Equipment
- Point-to-Point/Point-to-Multi-Point Radio
- Wideband Communication & Surveillance Systems
- Radar Warning Receivers

Features

- Small Signal Gain: >8 dB
- 65 GHz Distributed Amplifier
- Can be configured with and w/o Bias-Tees for Vd and Vg1 bias
- Low Power Dissipation:
 - 300 mW with Bias Tee @ Vdd = 5V
 - 360 mW w/o Bias Tee @ Vdd = 6V
 - 480 mW w/o Bias Tee @ Vdd = 8V
- Small Die Size: 1.2 x 1.0 x 0.1 mm

Functional Diagram

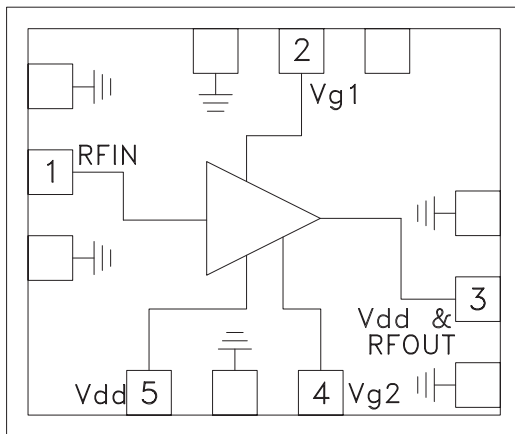

General Description

The HMC-AUH312 is a GaAs MMIC HEMT Distributed Driver Amplifier die which operates between 500 MHz and 65 GHz and provides a typical 3 dB bandwidth in excess of 65 GHz. The amplifier provides 10 dB of small signal gain and a maximum output amplitude of 2.5V peak to peak, which makes it ideal for use in broadband wireless, fiber optic communication and test equipment applications. The amplifier die occupies 1.2 mm² which facilitates easy integration into Multi-Chip-Modules (MCMs). The HMC-AUH312 can be used with or without a bias-tee and requires off-chip blocking components and bypass capacitors for the DC supply lines. Adjustable gate voltages allow for gain adjustment.

Electrical Specifications, $T_A = +25^\circ \text{C}$, Vdd= +8V *

Parameter	Min.	Typ.	Max.	Units
Frequency Range	0.5 - 65			GHz
Gain	8	10		dB
Input Return Loss		12		dB
Output Return Loss		15		dB
Supply Current (Idd) (Vdd= 8V)		60		mA

*Unless otherwise indicated, all measurements are from probed die

**GaAs HEMT MMIC MODULATOR
DRIVER AMPLIFIER, 0.5 - 65 GHz**

On-Wafer Gain vs. Frequency

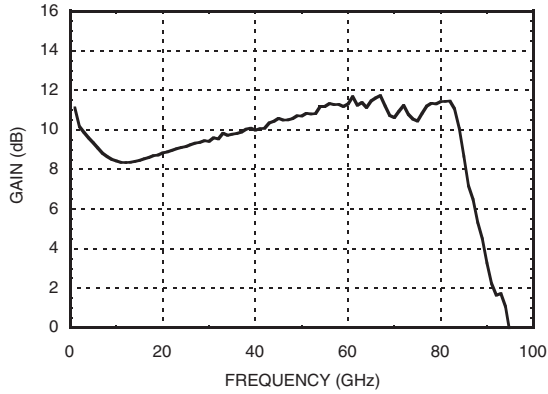

On-Wafer Group Delay vs. Frequency

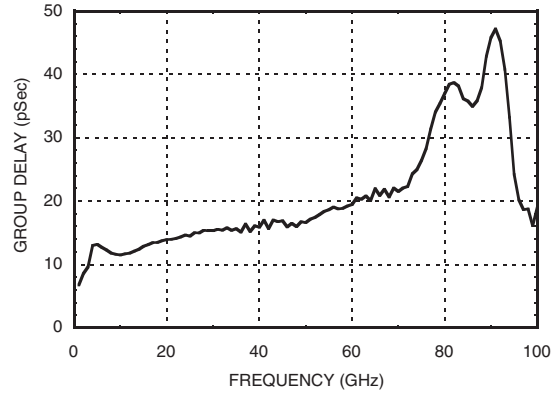

On-Wafer Input Return Loss vs. Frequency

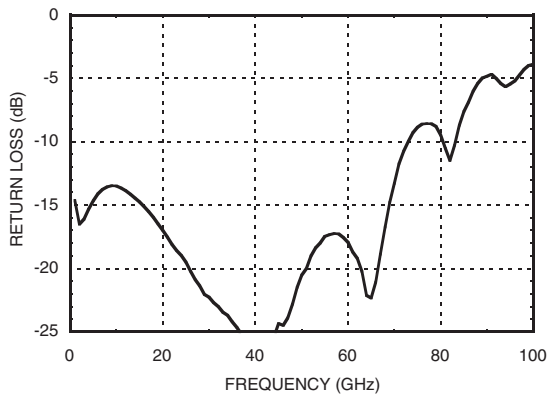

**On-Wafer
Output Return Loss vs. Frequency**

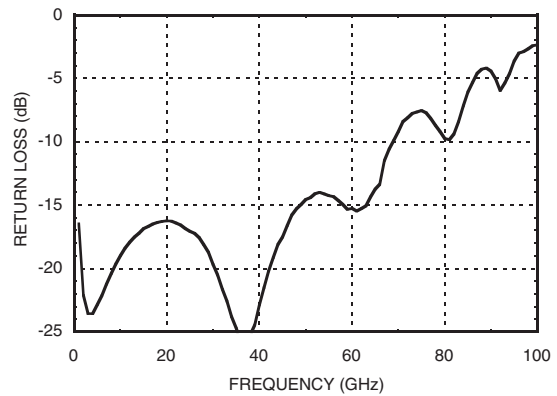

Note: Measured Performance Characteristics (Operating Temperature TA=25°C) Vdd = 6V, Vgg2 = 1.8V Idd = 60mA (On-Wafer)

For price, delivery, and to place orders, please contact Hittite Microwave Corporation:
20 Alpha Road, Chelmsford, MA 01824 Phone: 978-250-3343 Fax: 978-250-3373
Order On-line at www.hittite.com

GaAs HEMT MMIC MODULATOR DRIVER AMPLIFIER, 0.5 - 65 GHz

Absolute Maximum Ratings

Drain Bias Voltage w/ Bias Tee (Vdd)	+7 Vdc
Drain Bias Voltage w/out Bias Tee (Vdd)	+8.25 Vdc
Gain Bias Voltage (Vg1)	0.5V
Gain Bias Voltage (Vg2)	1.8V
RF Input Power	+10 dBm
Channel Temperature	180 °C
Storage Temperature	-40 to +85 °C
Operating Temperature	-0 to +70 °C

Recommended Operating Conditions w/ Bias Tee

Parameter	Min.	Typ.	Max.	Units
Positive Supply Voltage	3	5	6	V
Positive Supply Current		60	80	mA
Gate Voltage (Vg1)	-1		0.3	V
Gate Voltage (Vg2)		1.8		V
RF Input Power			4	dBm
Operating Temperature	0	25	70	°C

Recommended Operating Conditions w/out Bias Tee

Parameter	Min.	Typ.	Max.	Units
Positive Supply Voltage	5	8	8.25	V
Positive Supply Current		60	65	mA
Gate Voltage (Vg1)	-1		0.5	V
Gate Voltage (Vg2)	1	1.8		V
RF Input Power			4	dBm
Operating Temperature	0	25	70	°C



ELECTROSTATIC SENSITIVE DEVICE
OBSERVE HANDLING PRECAUTIONS

Outline Drawing

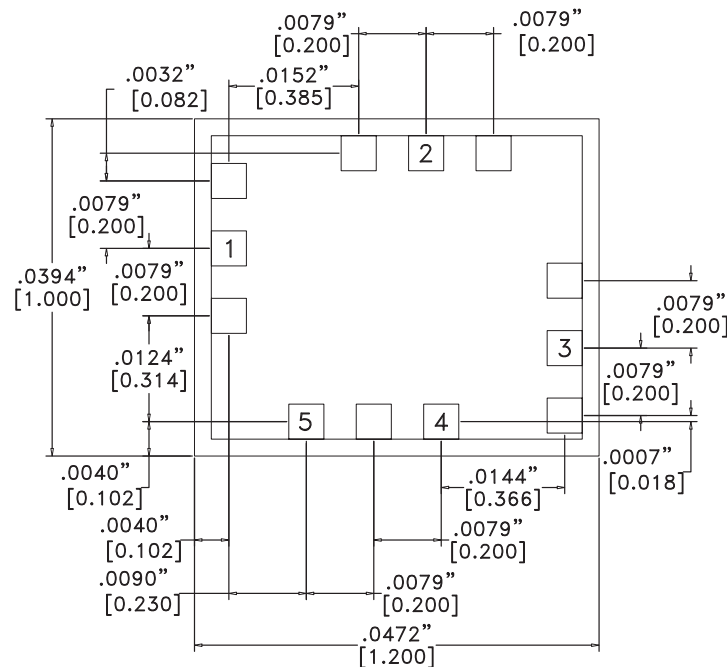

Die Packaging Information [1]

Standard	Alternate
GP-2 (Gel Pack)	[2]

[1] Refer to the "Packaging Information" section for die packaging dimensions.

[2] For alternate packaging information contact Hittite Microwave Corporation.



NOTES:

- ALL DIMENSIONS ARE IN INCHES [MM].
- TYPICAL BOND PAD IS .004" SQUARE.
- BACKSIDE METALLIZATION: GOLD.
- BACKSIDE METAL IS GROUND.
- BOND PAD METALLIZATION: GOLD.
- CONNECTION NOT REQUIRED FOR UNLABELED BOND PADS.
- OVERALL DIE SIZE ±.002"

For price, delivery, and to place orders, please contact Hittite Microwave Corporation:
20 Alpha Road, Chelmsford, MA 01824 Phone: 978-250-3343 Fax: 978-250-3373
Order On-line at www.hittite.com

**GaAs HEMT MMIC MODULATOR
DRIVER AMPLIFIER, 0.5 - 65 GHz**

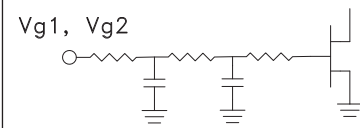
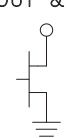
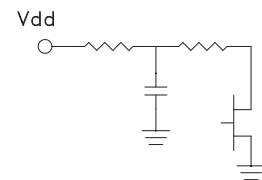
Pad Descriptions

Pad Number	Function	Description	Interface Schematic
1	RFIN	DC coupled. An off chip blocking cap is needed.	RFIN 
2, 4	Vg1, Vg2	Gate control for amplifier. Please follow "MMIC Amplifier Biasing Procedure" application note. See assembly for required external components.	Vg1, Vg2 
3	Vdd, RFOUT	RF output and DC bias (Vd) for the output stage.	RFOUT & Vdd 
5	Vdd	Supply voltage for amplifier. See assembly diagram for external components.	Vdd 
Die Bottom	GND	Die Bottom must be connected to RF/DC ground.	GND 

**GaAs HEMT MMIC MODULATOR
DRIVER AMPLIFIER, 0.5 - 65 GHz**

Assembly Drawing

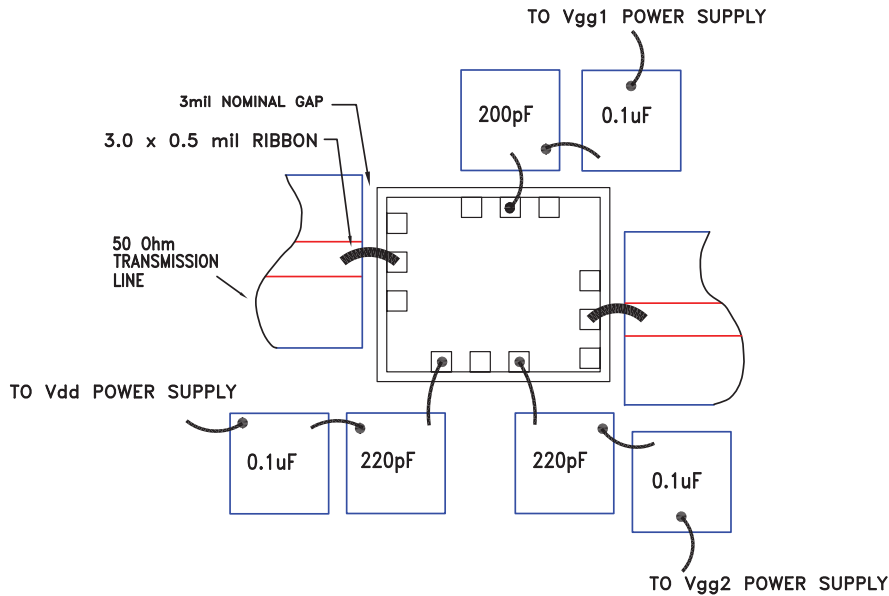

Suggested Alternate Assembly

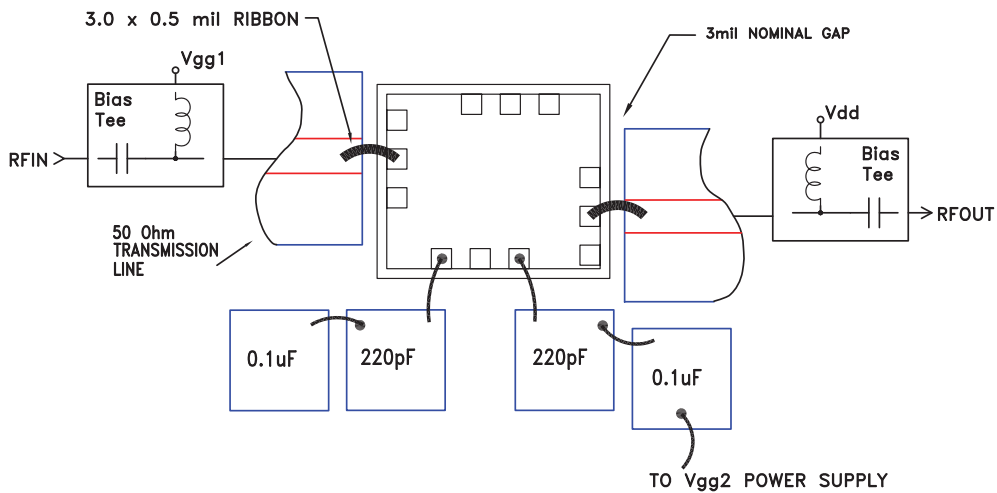

GaAs HEMT MMIC MODULATOR DRIVER AMPLIFIER, 0.5 - 65 GHz

Device Mounting

- 1 mil wire bonds are used on Vg1, Vg2 connections to the capacitors.
- 0.5mil x 3mil ribbon bonds are used on all other connections
- Capacitors on Vg1, Vg2 are used to filter low frequency, <800MHz, RF pickup
- For best gain flatness and group delay variation, the capacitors off of Vdd, Vg1 and Vg2 should be placed as close to the die as possible so as to minimize bond wire parasitics. Vdd is especially sensitive to the bond parasitics.
- Silver-filled conductive epoxy is used for die attachment. (Backside of the die should be grounded and the GND pads are connected to the backside metal through Vias)

Device Operation

- These devices are susceptible to damage from Electrostatic Discharge. Proper precautions should be observed during handling, assembly and test.
- The input and output to this device should be AC-coupled.

Device Power Up Instructions

1. Ground the device
2. Bring Vg2 to +1.8V (no drain current)
3. Turn on Vdd to 0V. Bring Vdd to +8V (+5V if a bias tee is used to for Vd bias). +6V is minimum recommended Vdd
4. Turn on Vg1 to 0V. Adjust Vg1 should be adjusted to bring Id to 60mA.

Device Power Down Instructions

1. Reverse the sequence identified above in steps 1 through 4.

**GaAs HEMT MMIC MODULATOR
DRIVER AMPLIFIER, 0.5 - 65 GHz**

Mounting & Bonding Techniques for Millimeterwave GaAs MMICs

The die should be attached directly to the ground plane eutectically or with conductive epoxy (see HMC general Handling, Mounting, Bonding Note).

50 Ohm Microstrip transmission lines on 0.127mm (5 mil) thick alumina thin film substrates are recommended for bringing RF to and from the chip (Figure 1). If 0.254mm (10 mil) thick alumina thin film substrates must be used, the die should be raised 0.150mm (6 mils) so that the surface of the die is coplanar with the surface of the substrate. One way to accomplish this is to attach the 0.102mm (4 mil) thick die to a 0.150mm (6 mil) thick molybdenum heat spreader (moly-tab) which is then attached to the ground plane (Figure 2).

Microstrip substrates should be placed as close to the die as possible in order to minimize bond wire length. Typical die-to-substrate spacing is 0.076mm to 0.152 mm (3 to 6 mils).

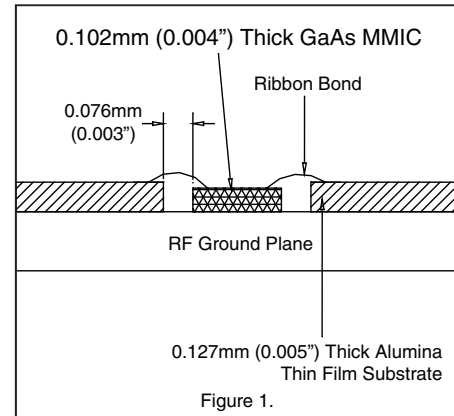

Handling Precautions

Follow these precautions to avoid permanent damage.

Storage: All bare die are placed in either Waffle or Gel based ESD protective containers, and then sealed in an ESD protective bag for shipment. Once the sealed ESD protective bag has been opened, all die should be stored in a dry nitrogen environment.

Cleanliness: Handle the chips in a clean environment. DO NOT attempt to clean the chip using liquid cleaning systems.

Static Sensitivity: Follow ESD precautions to protect against ESD strikes.

Transients: Suppress instrument and bias supply transients while bias is applied. Use shielded signal and bias cables to minimize inductive pick-up.

General Handling: Handle the chip along the edges with a vacuum collet or with a sharp pair of bent tweezers. The surface of the chip has fragile air bridges and should not be touched with vacuum collet, tweezers, or fingers.

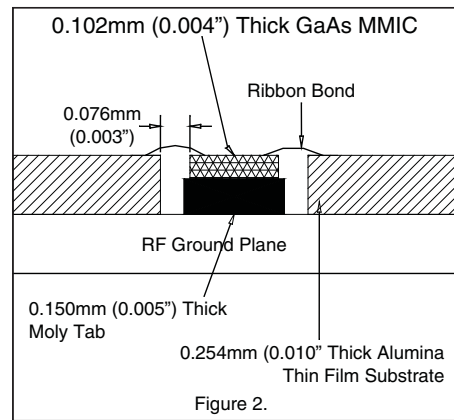

Mounting

The chip is back-metallized and can be die mounted with AuSn eutectic preforms or with electrically conductive epoxy. The mounting surface should be clean and flat.

Eutectic Die Attach: A 80/20 gold tin preform is recommended with a work surface temperature of 255 °C and a tool temperature of 265 °C. When hot 90/10 nitrogen/hydrogen gas is applied, tool tip temperature should be 290 °C. DO NOT expose the chip to a temperature greater than 320 °C for more than 20 seconds. No more than 3 seconds of scrubbing should be required for attachment.

Epoxy Die Attach: Apply a minimum amount of epoxy to the mounting surface so that a thin epoxy fillet is observed around the perimeter of the chip once it is placed into position. Cure epoxy per the manufacturer's schedule.

Wire Bonding

RF bonds made with 0.003" x 0.0005" ribbon are recommended. These bonds should be thermosonically bonded with a force of 40-60 grams. DC bonds of 0.001" (0.025 mm) diameter, thermosonically bonded, are recommended. Ball bonds should be made with a force of 40-50 grams and wedge bonds at 18-22 grams. All bonds should be made with a nominal stage temperature of 150 °C. A minimum amount of ultrasonic energy should be applied to achieve reliable bonds. All bonds should be as short as possible, less than 12 mils (0.31 mm).

**GaAs HEMT MMIC MODULATOR
DRIVER AMPLIFIER, 0.5 - 65 GHz**

Notes